



# Building Automation System Basics

EngineeringAdvantage™ Program

Presented by Brendan Cox

October 2024

Siemens Building Technologies, Inc. is a Registered Provider with The American Institute of Architects Continuing Education Systems. Credit earned on completion of this program will be reported to CES Records for AIA members.

Certificates of Completion for non-AIA members are available on request.

This program is registered with the AIA/CES for continuing professional education. As such, it does not include content that may be deemed or constructed to be an approval or endorsement by the AIA of any material of construction or any method or manner of handling, using, distributing, or dealing in any material or product.

Questions related to specific materials, methods, and services will be addressed at the conclusion of this presentation.

AIA LU/HSW Credit

AIA/CES



# Course Description

## **Building Automation System Basics (BAS101)**

Most buildings designed and built today have some means of managing and controlling building systems through a Building Automation System (BAS). This presentation will cover basic terms and components comprising a typical commercial building system.

## **Learning Objectives**

- Learn about the basics of Building Automation Systems
- Understand the concept of a BAS Point
- Be able to identify various components
- Recognize how the components and controllers form a BAS Control System

# Course Outline



- Background
- Control Fundamentals
- Key Elements of BAS System
- Trends
- Wrap-up

# Defining a Building Automation System (BAS)

## Building Automation System

A built combination of electronic hardware, instrumentation, low-voltage cabling, data, and software that control and monitor a building's systems to keep occupants comfortable, healthy, and safe.

### Division 23

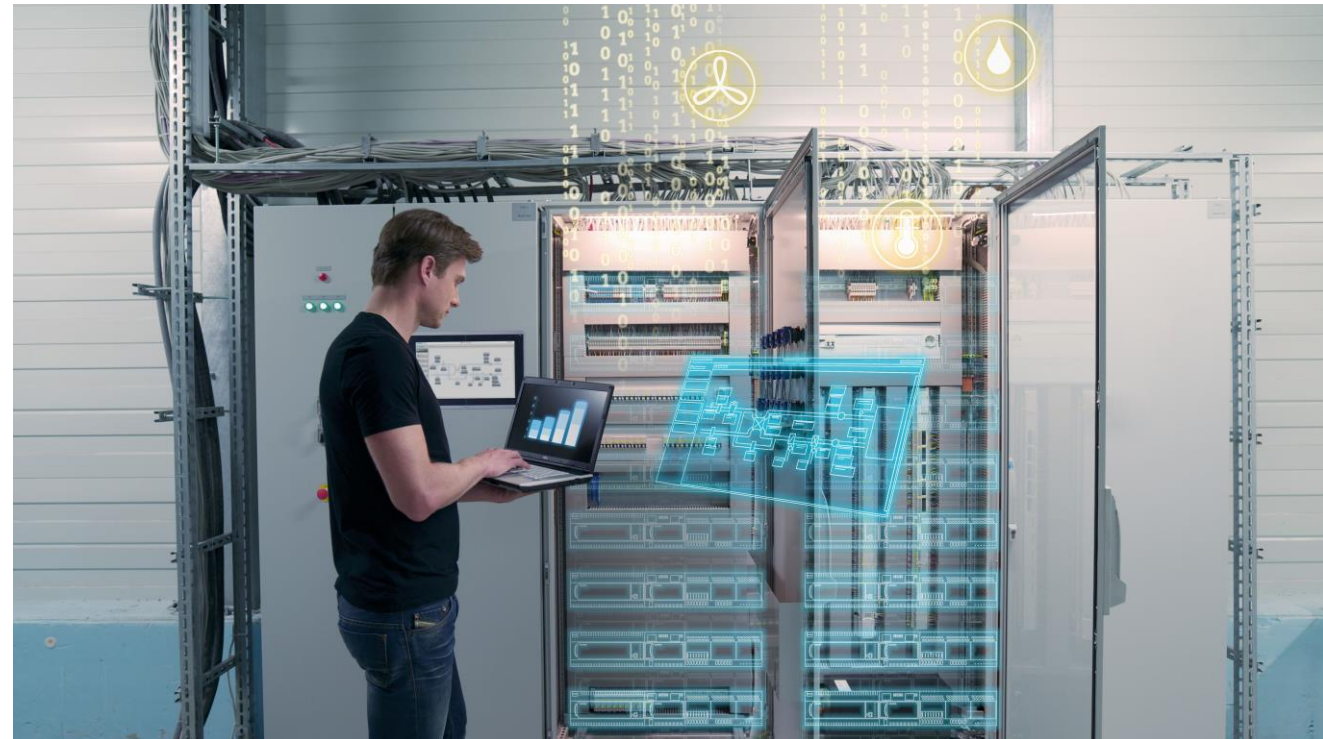

# Defining a Building Automation System (BAS)

Interconnected

DDC Controls

“Front end”

Automated

## Criteria

- Utilizes Direct Digital Controls (DDC)
- Has a central user interface (“front end” or “head end”)
- Multiple building systems/equipment are interconnected
- Automated to maintain building conditions to design criteria with minimal human intervention

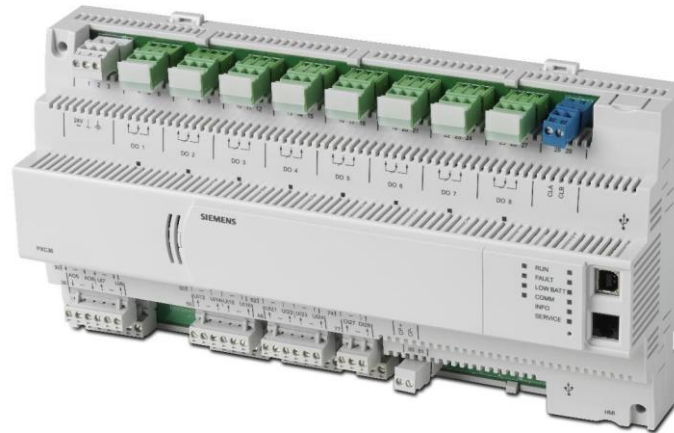

```
7 string sInput;
8 int iLength, iN;
9 double dblTemp;
10 bool again = true;
11
12 while (again) {
13     iN = -1;
14     again = false;
15     getline(cin, sInput);
16     system("cls");
17     stringstream(sInput) >> dblTemp;
18     iLength = sInput.length();
19     if (iLength < 4) {
20         again = true;
21         continue;
22     } else if (sInput[iLength - 3] != '.') {
23         again = true;
24         continue;
25     } while (++iN < iLength) {
26         if (isdigit(sInput[iN])) {
27             continue;
28         } else if (iN == (iLength - 3)) {
29
30
31
32
33
34
35
```

## Defining a Building Automation System (BAS) - examples

Scenario:

Package rooftop unit (RTU) with manufacturer's standalone, digital, programmable thermostat

- Uses DDC?
- Has a user interface?
- Interconnected?
- Automated?

This system could be tied into a larger BAS, but is not in itself an “automation system” per se.



## Defining a Building Automation System (BAS) - examples



Scenario:

Large chiller plant utilizing microprocessor-based controls with “front end” workstation accessible by facilities director in his office. The director can change setpoints, schedules, setbacks, etc., remotely.



- Uses DDC?
- Has a user interface?
- Interconnected?
- Automated?

## Three tiers of BAS capabilities

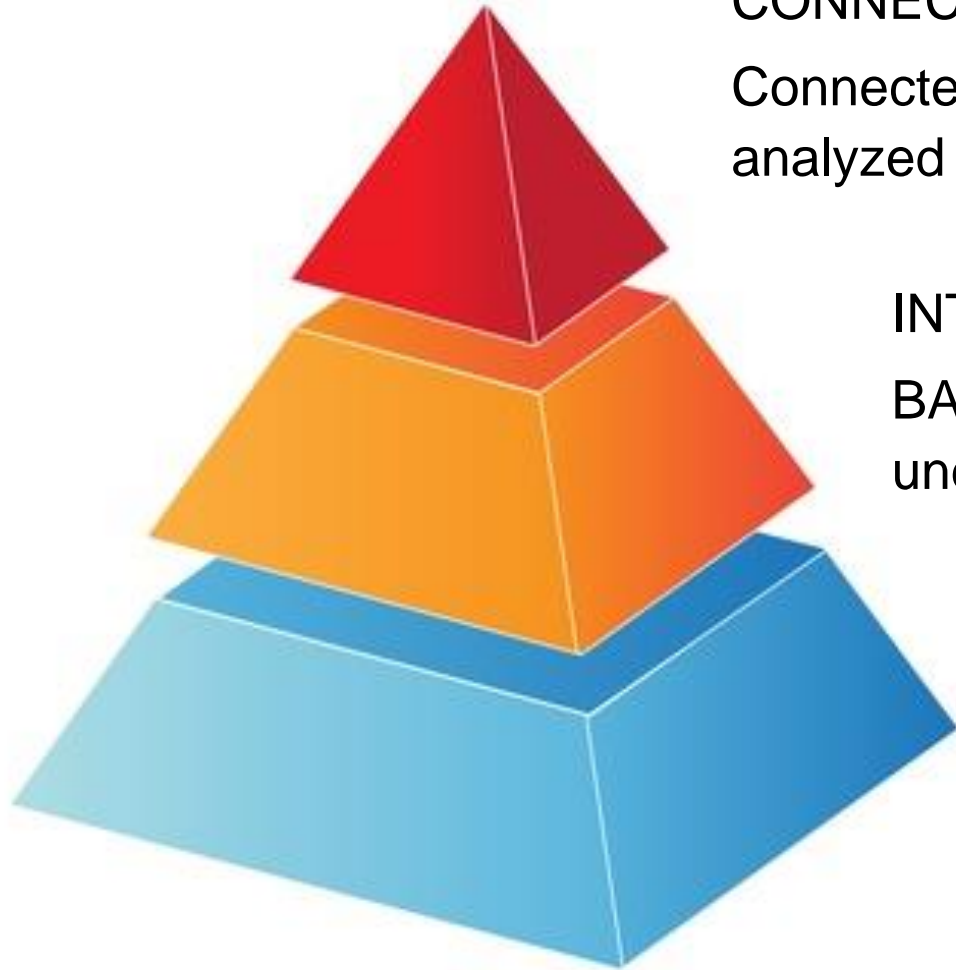

### CONNECTED

Connected to digital/data tools and continuously analyzed to optimize efficiency

### INTEGRATED

BAS is monitoring other systems not directly under its control; operators gain insights

### CONTROLLED

Processes are under control to create desired conditions in the building

## Three tiers of BAS capabilities - example

### CONTROLLED

- “Hardwire” connected to BAS for on/off and speed control, and general alarm

### INTEGRATED

- BACnet card is connected to BAS and advanced points (kWh, runtime, specific alarms)

### CONNECTED

- Advanced, custom alarms alert owner of unusual energy usage compared to trends, e.g.
- Predictive maintenance recommended based on analysis of data and historical performance



# BAS Basics – Yesterday to Tomorrow

Building Evolution

Technology Evolution

User Needs

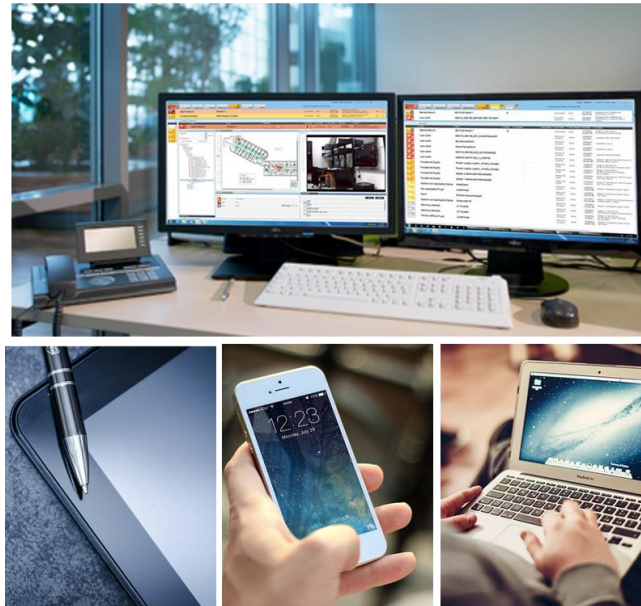

# BAS Basics – Yesterday to Tomorrow

Building Evolution

Technology Evolution

User Needs



- Net-Zero & Bioclimatic
- Offices to flexible workspace
- Bed Towers to Treatment Centers
- Classrooms to High Tech Learning
- Server Rooms to Data Centers

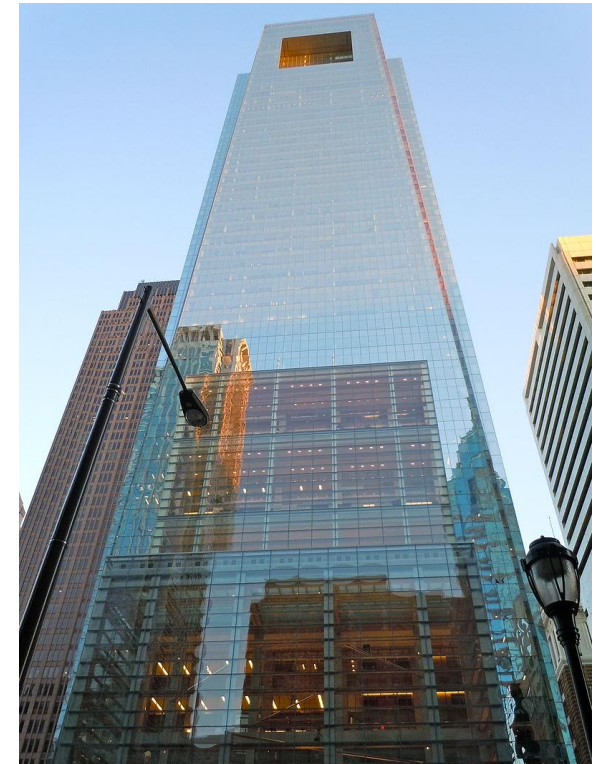

# BAS Basics – Yesterday to Tomorrow

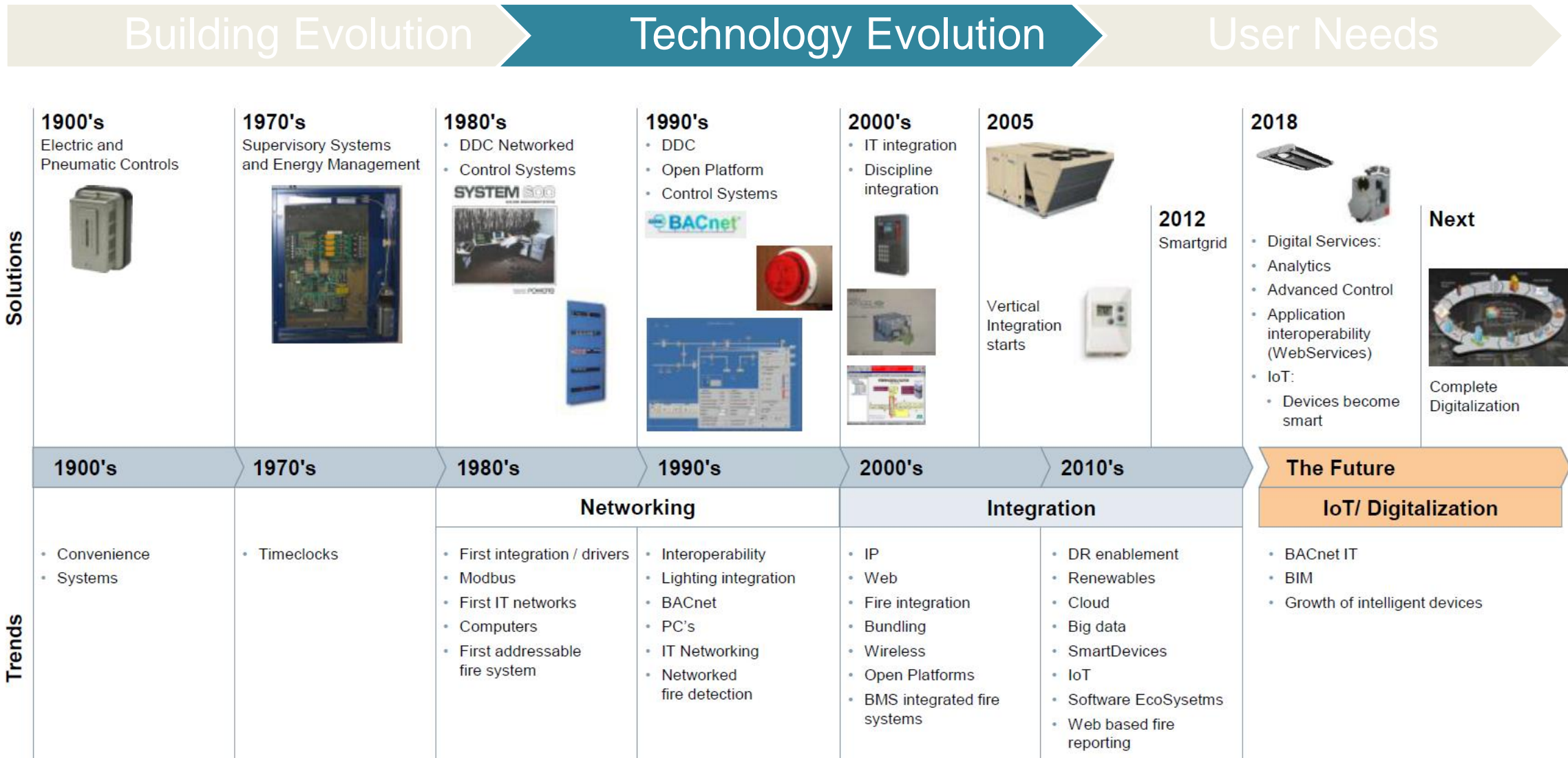

# BAS Basics – Yesterday to Tomorrow

Building Evolution

Technology Evolution

User Needs



- Environmental Quality
- Precise Control
- Complex Energy Management
- Data Collection
- Flexible Data Media
- Mobile Data
- Paradigm Shift – IoT, Wireless, Big Data

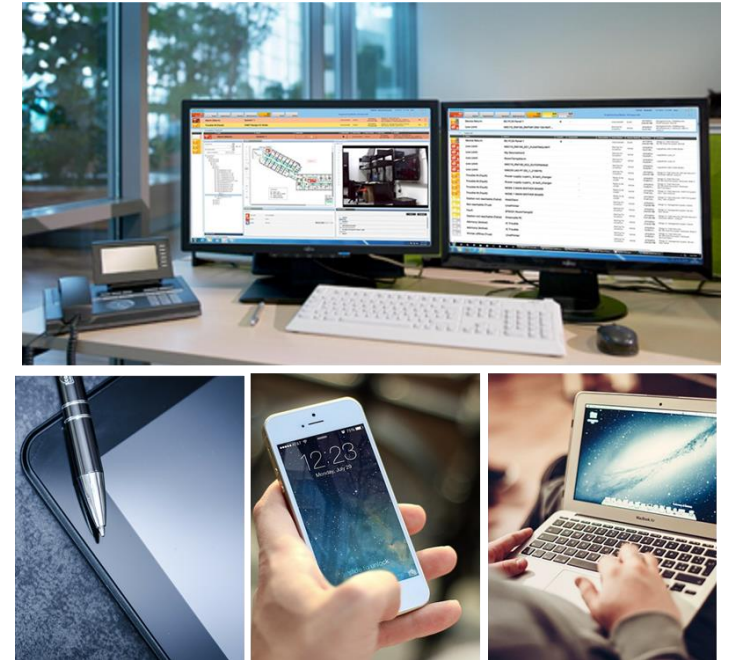

The background features a perspective view of a tunnel formed by concentric rings of binary code (0s and 1s) that recede into the distance. At the center of this tunnel is a bright, glowing white sphere. Overlaid on the right side of the image is a solid teal circle with a white border. Inside this circle, the text "Control Fundamentals" is written in a clean, white, sans-serif font.

# Control Fundamentals

## Control Fundamentals – Basic Control Loop



Basic Control Loop

# Control Fundamentals – Basic Control Loop

## Closed Loop

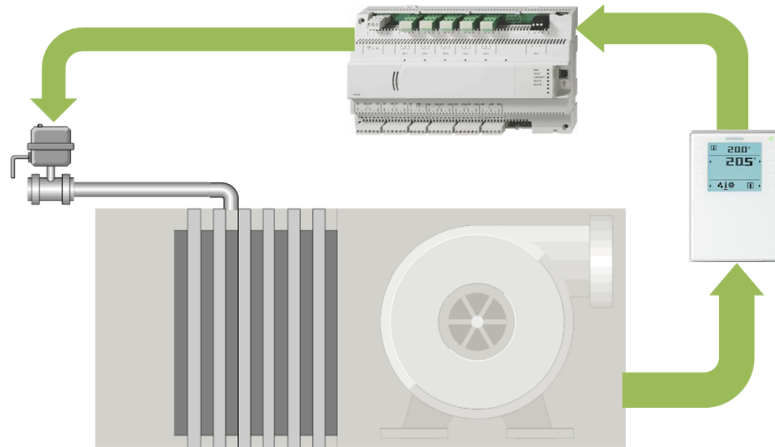
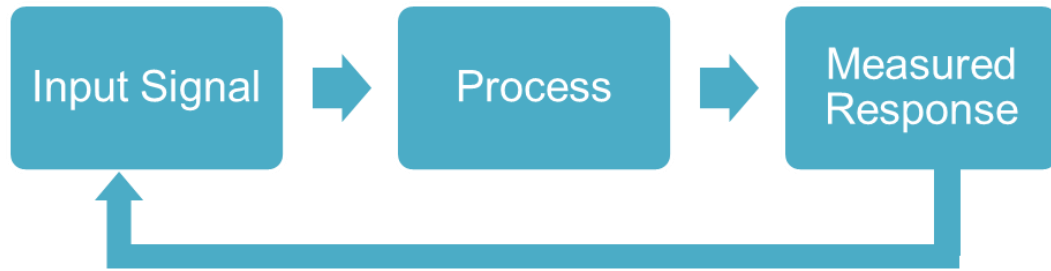

## Open Loop

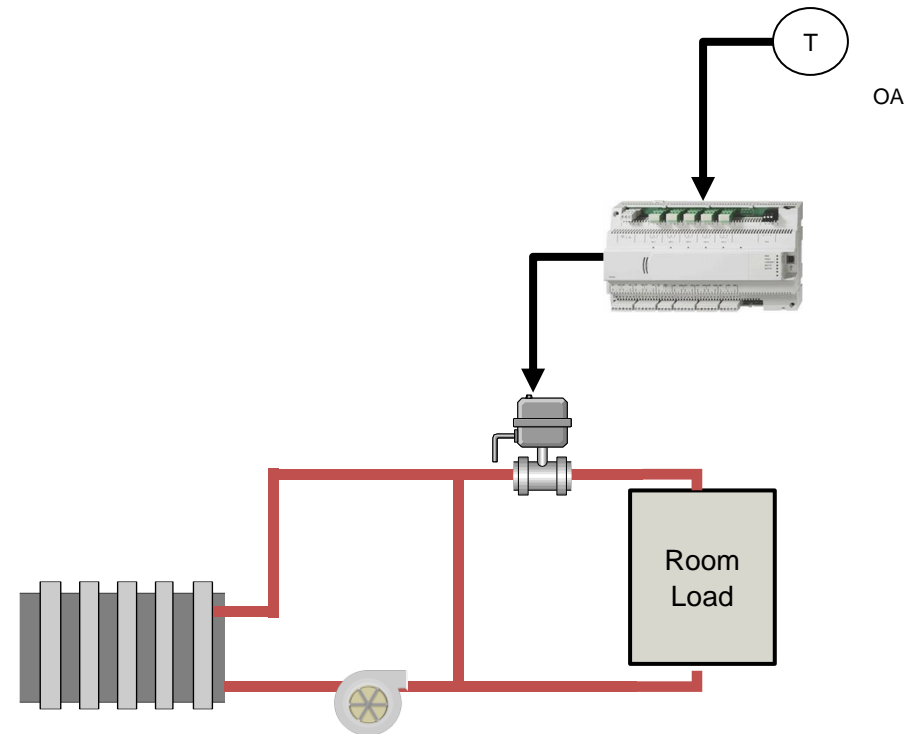

## Direct Digital Control (DDC) Control Loops – PID Loops Defined

**P** Proportional control = variable output change in proportion to the varying input (direct or reverse)

**I** Integral add = measures offset over time and adjust until zero

**D** Derivative add = predictive element by measuring slope of response (*rarely used*)

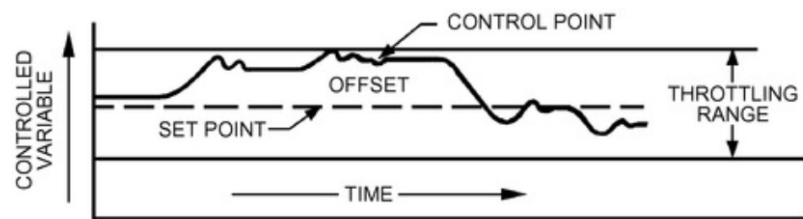

Proportional Control

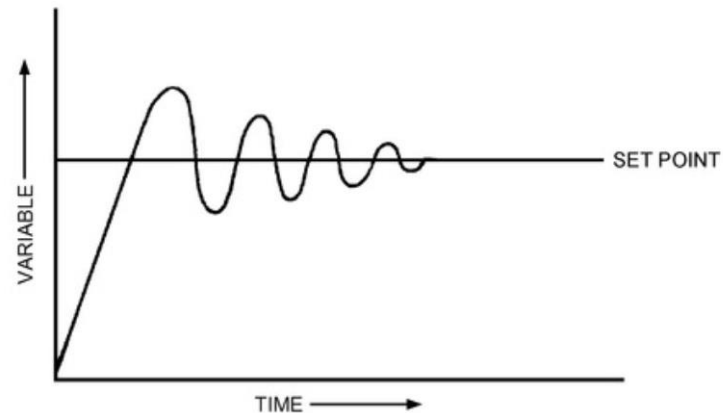

Proportional + Integral Control

### Results:

P Loop settles with an error from setpoint

PI Control variable offset close to setpoint, output maintained

PID Gets there faster

# Control Fundamentals – Typical Control Responses

Two – Position: Same as "digital"; switch; on-off; open/close

Proportional: Analog or variable output in proportion to varying input; direct or reverse acting; range converted to volts or amps (e.g. 0-100%, 0-10V, 2-10V, or 4-20mA)

Pulse Width Modulation (PWM): Form of analog, range is converted to time pulse (e.g. 50% open = 25ms pulse); monitors a timed closure of a set of contacts

Floating – Form of “analog”, range is converted to time, two outputs increase or decrease with a dead band between. Requires Slow actuator/Fast responding sensor

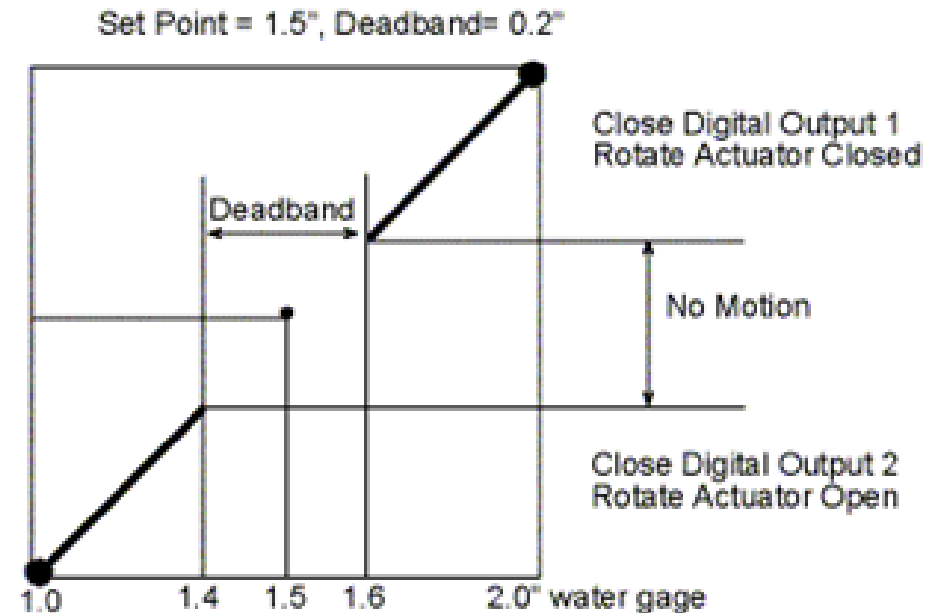
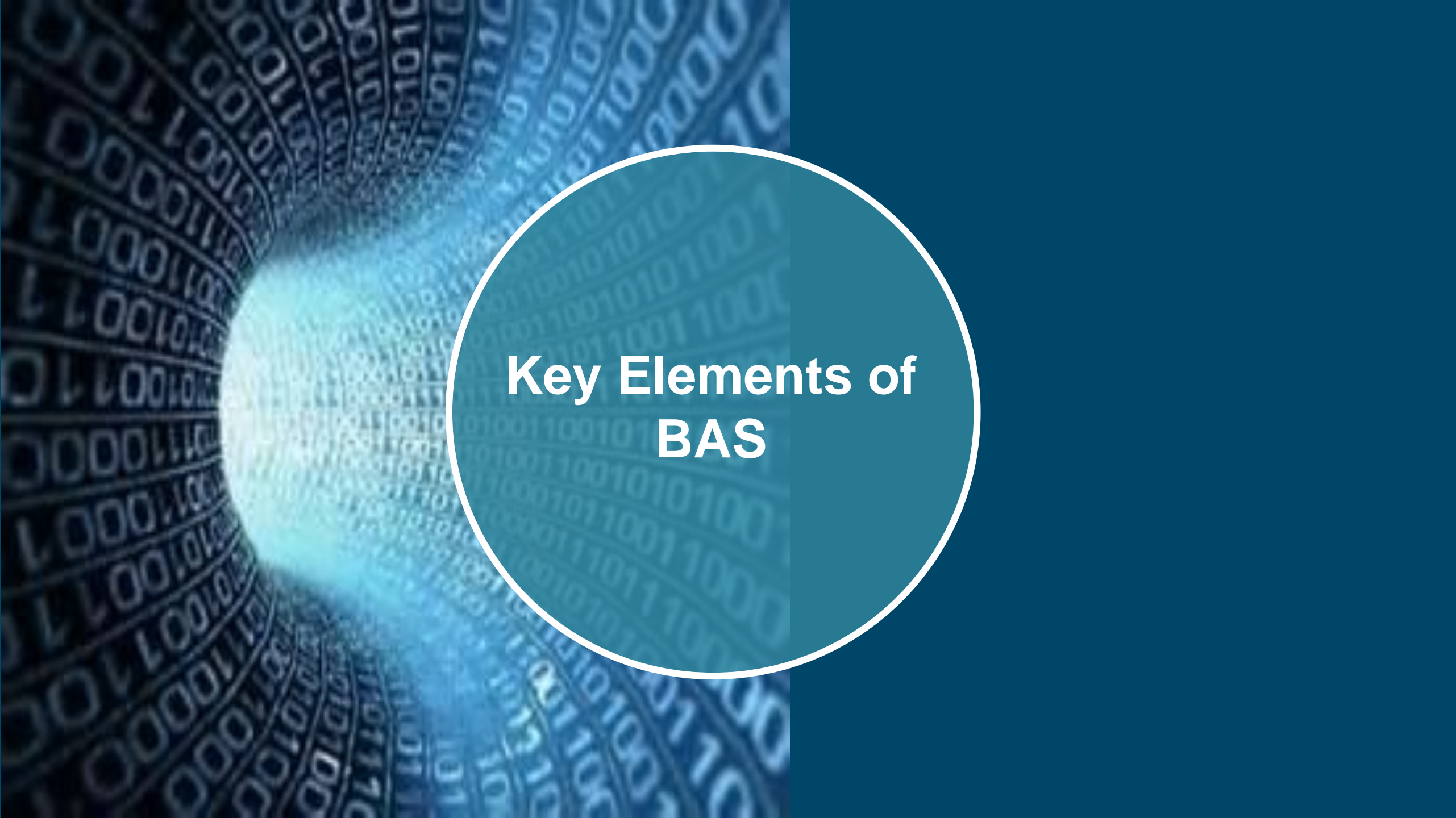

Image credit DDC-Online



**Key Elements of  
BAS**

# BAS Key Elements

Management Level

Automation Level

Field Level

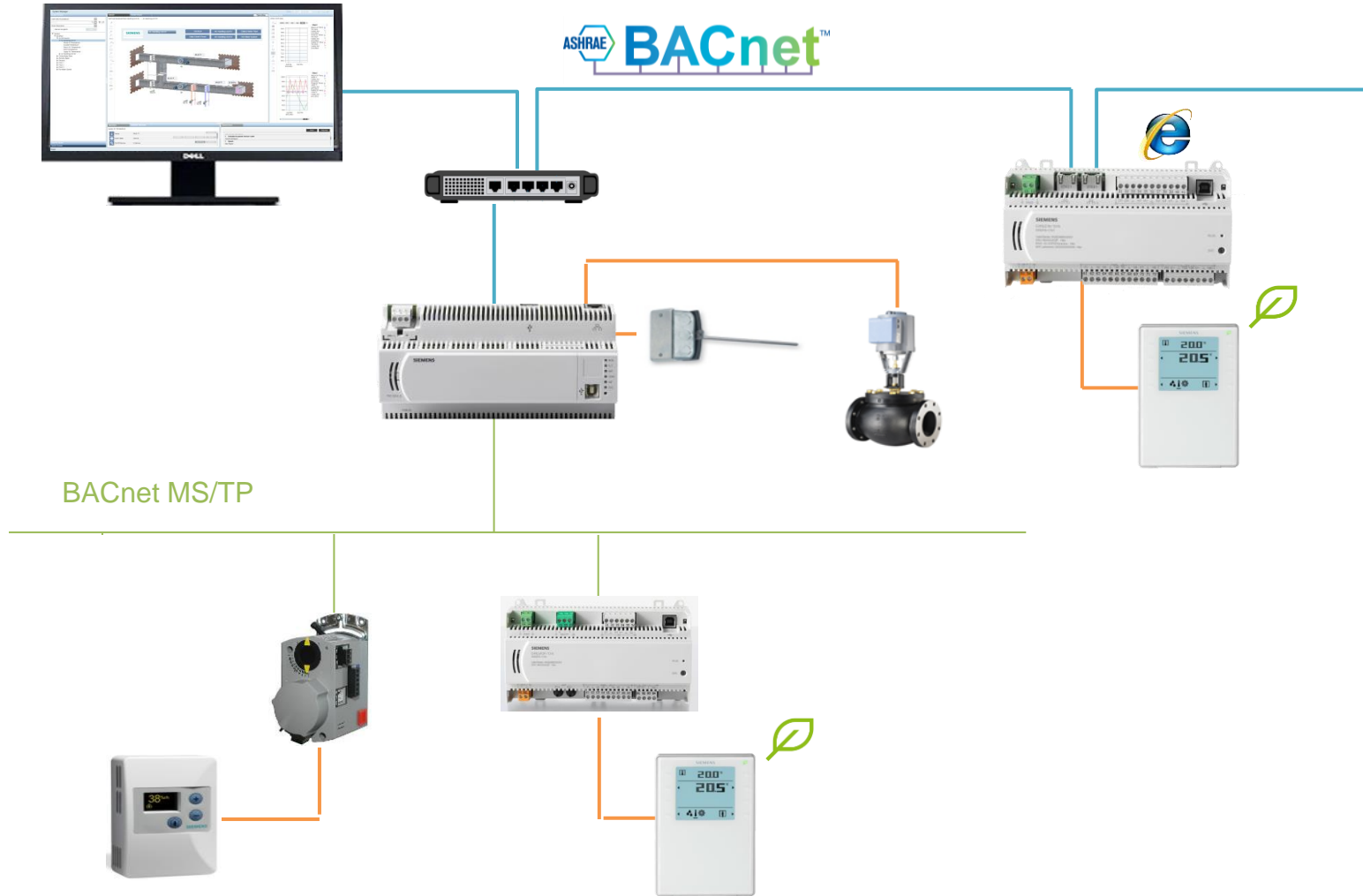

Communication Network

BAS Hardware

Field Devices

# BAS Key Elements – Field Devices

Management Level

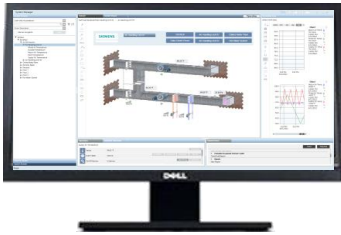

ASHRAE BACnet™



Automation Level

BACnet MS/TP

Field Level

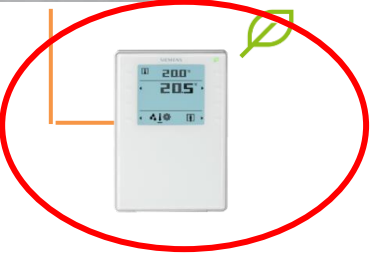

Field Devices  
Or  
Control Components

# Field Devices DDC Points (Hardwired) – Data Type and Data Flow

Analog Input (AI)



Variable information such as temperature, humidity, pressure, flow, power

Digital Input (DI)



Two state information generally indicating status such as safeties, on/off

Analog Output(AO)



Modulating control, such as dampers, valves, VFDs

Digital Output (DO)



Two state control changing/maintaining status such as on/off, open/close

Inputs and Outputs are relative to the controller

\*Digital Points are also referred as “Binary” and sometimes used interchangeably.

# Instrumentation Drawings

Fundamental

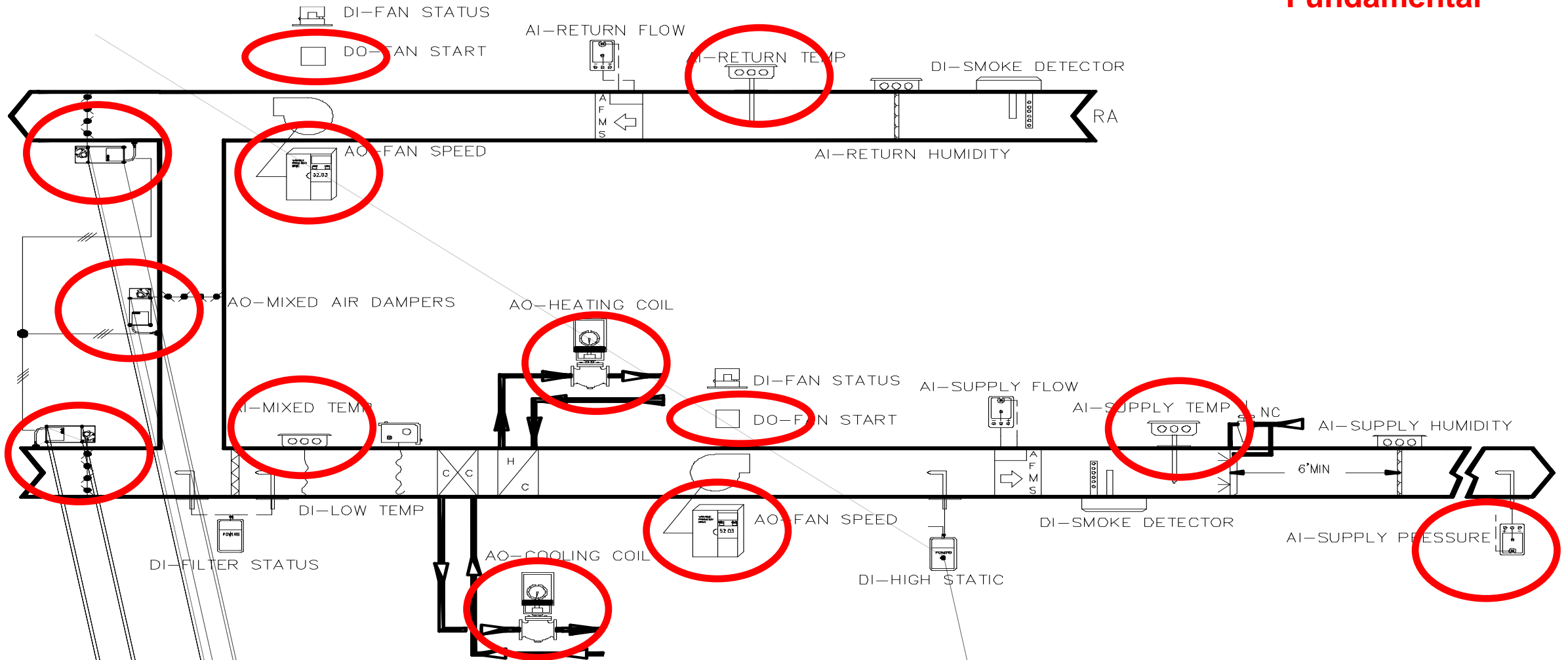

# Instrumentation Drawings

## Safeties

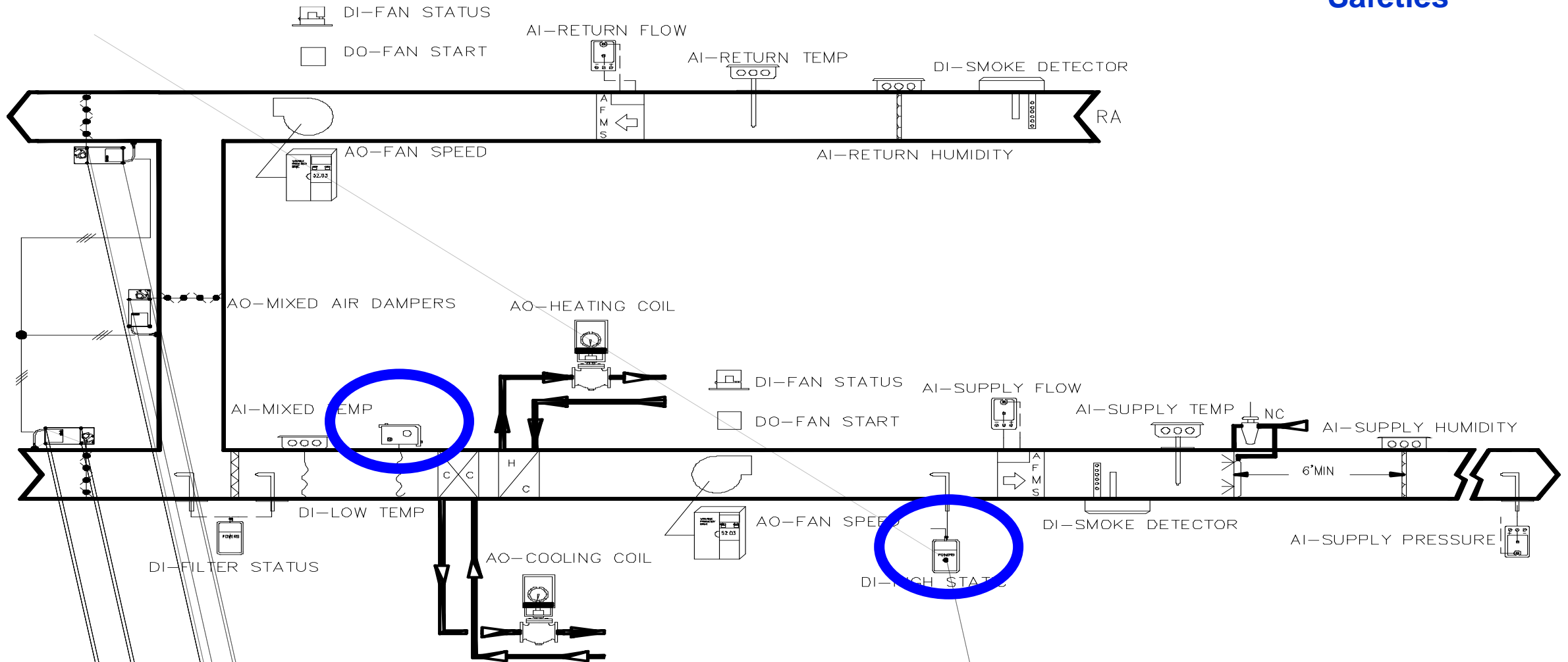

# Instrumentation Drawings

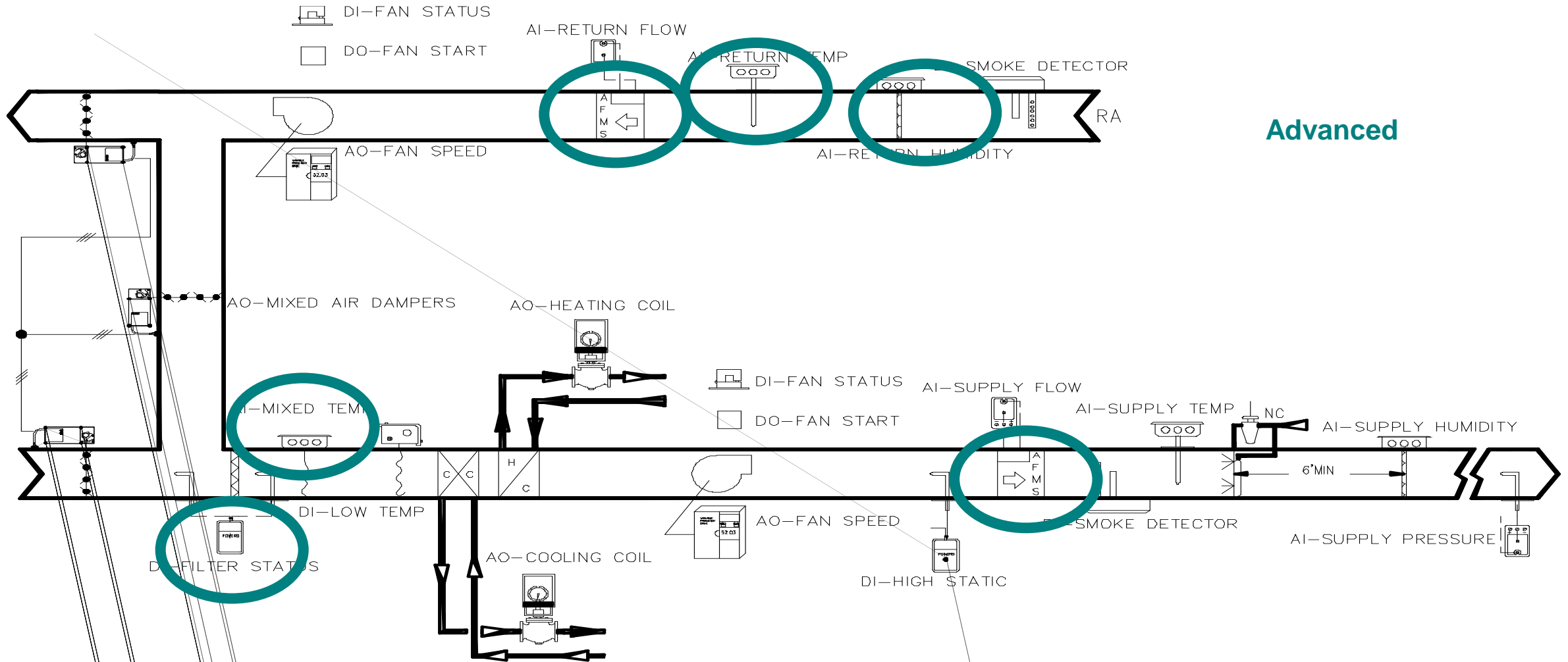

Advanced

# BAS Key Elements – DDC Hardware

Management Level

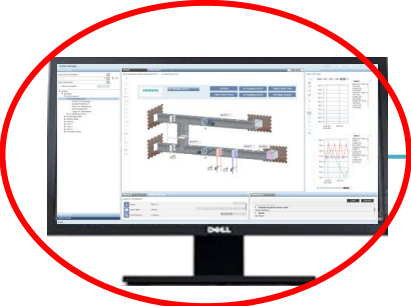

ASHRAE BACnet™

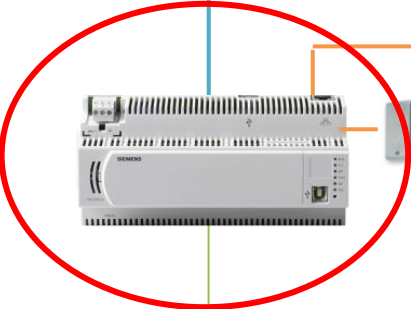

Sensor



Control Valve



Rom Unit



Automation Level

BACnet MS/TP

Field Level



# DDC Controller Basics – Points (Type, Flow, Source)

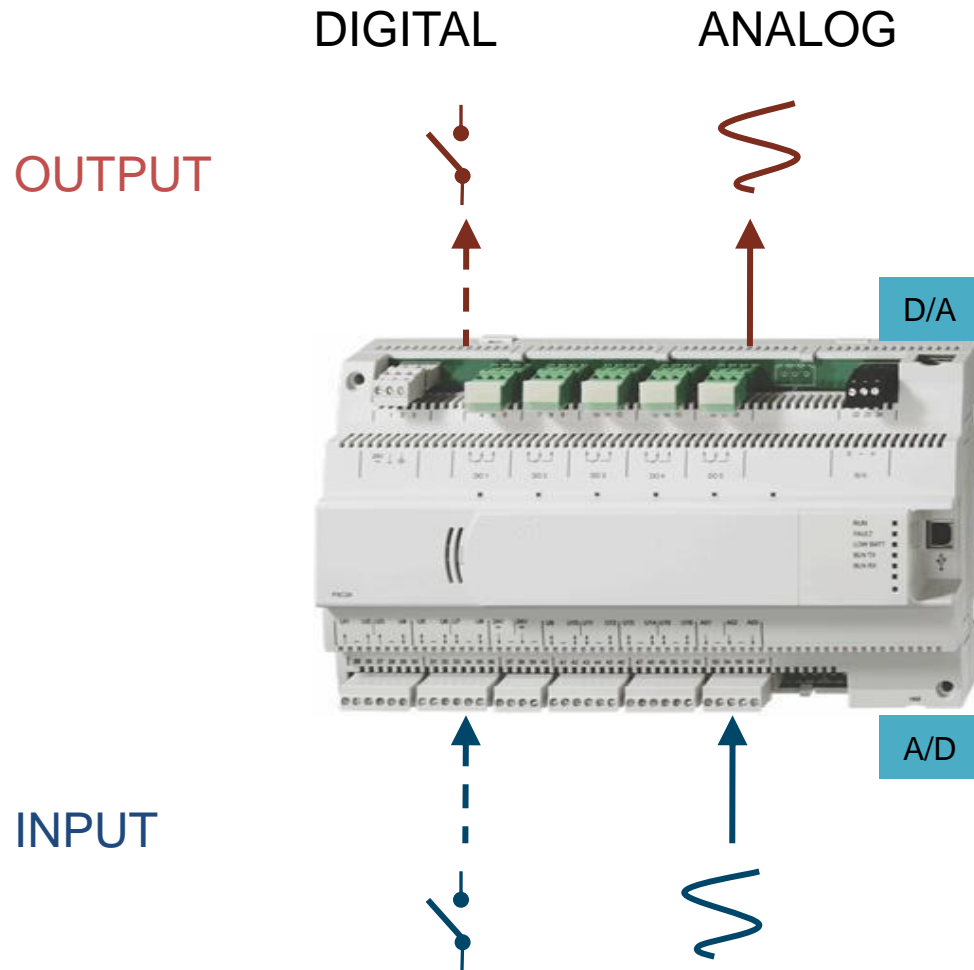

- POINT = Digital Representation of Signal
- Data Type: digital, analog, or accumulating
- Data Flow: input or output of component
- Data Source: External (hardwired), Internal (virtual/software)
- Source: Real (Hardwired) or Virtual (Software)
- Real: DI, DO, AI, AO
- Virtual: DV, AV

**FANSTR**  
**0.1.0.0.2**

Point Name  
Point Address



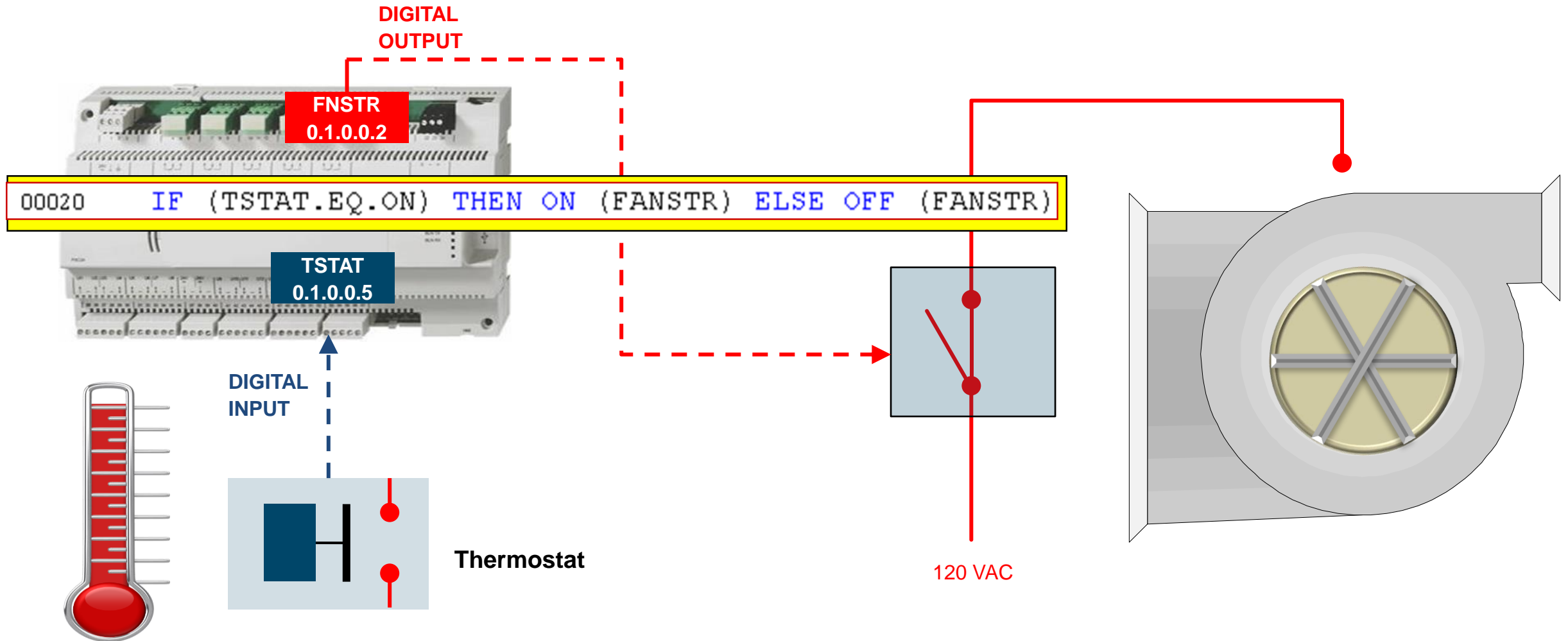

# DDC Controller Basics - Digital Points Data Flow

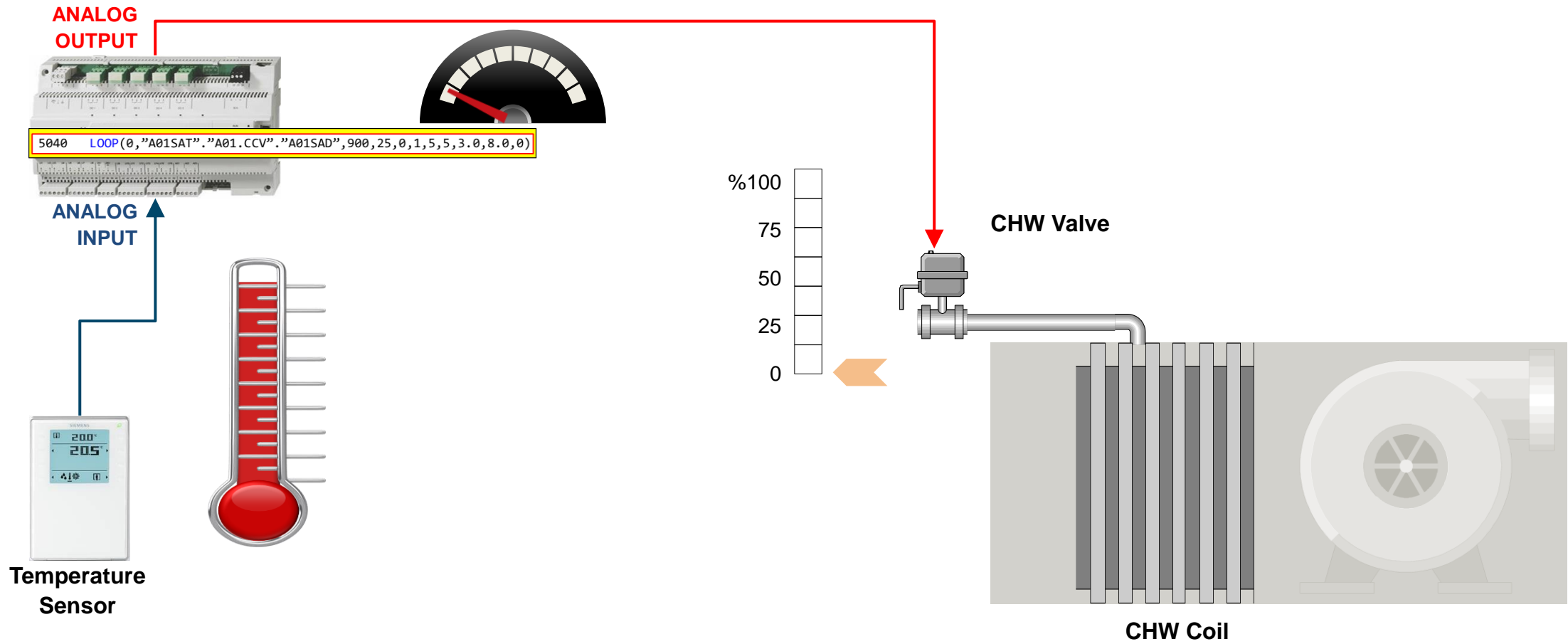

# DDC Controller Basics - Analog Points Data Flow

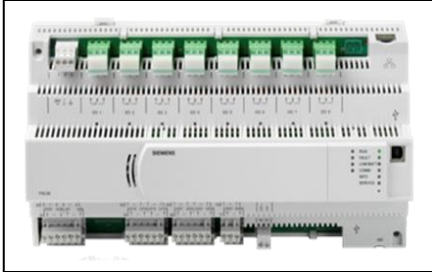
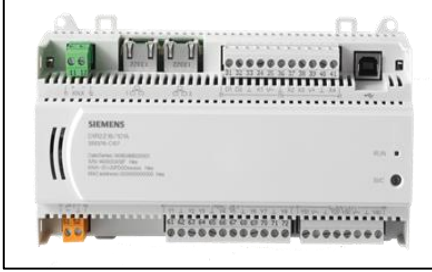

# DDC Controller Basics – General Controller Types and Functions

Controller Type	Typical Functions	Typical Applications
<p>Building Controller</p> 	<ul style="list-style-type: none"> <li>• Completely Stand-alone</li> <li>• Global Commanding</li> <li>• Network Management</li> <li>• Device Management</li> <li>• Custom Programming</li> <li>• Data sharing</li> <li>• Trending and Scheduling</li> <li>• Alarm Management</li> <li>• Event Management</li> <li>• Inputs/Outputs (opt)</li> <li>• Protocol Gateway</li> </ul>	<ul style="list-style-type: none"> <li>• Central Plants</li> <li>• Air Handling Units</li> <li>• Complex Room Control</li> <li>• Network Controller</li> </ul>
<p>Custom Application Controller</p> 	<ul style="list-style-type: none"> <li>• Stand-alone to perform its application (database)</li> <li>• Built in programs/applications</li> <li>• Custom programming</li> <li>• May have some level of scheduling</li> <li>• May have some level of trending</li> </ul>	<ul style="list-style-type: none"> <li>• Air Handling Units</li> <li>• Heating/Cooling Eqpt</li> <li>• Integrated Room Control</li> <li>• Complex Room Control</li> </ul>
<p>Application Specific Controller</p> 	<ul style="list-style-type: none"> <li>• Stand-alone to perform its application (database)</li> <li>• Built in program</li> <li>• Configurable</li> <li>• May have some level of scheduling/trending but relies primarily on higher level</li> </ul>	<ul style="list-style-type: none"> <li>• VAV boxes</li> <li>• Fan Coil Units</li> <li>• Heat Pumps</li> <li>• Unit Ventilators</li> <li>• Unit Conditioners</li> </ul>

# BAS Key Elements - Workstation



Graphics

Data Exchange

Scheduling

Trend setup and storage

Alarms setup and history

Reports setup and storage

# BAS Key Elements – Network Communication

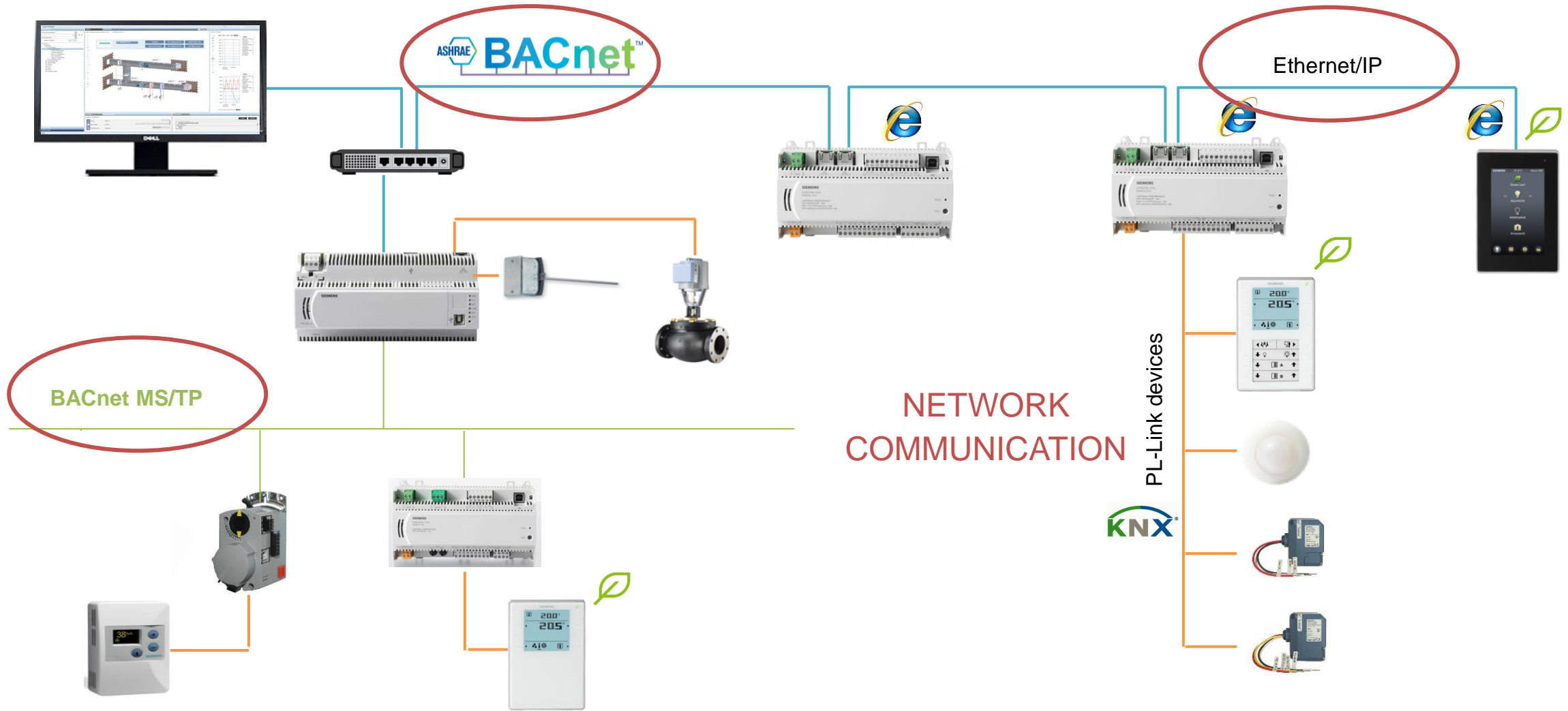

# Network Communication - Protocols

- Protocol – Set of rules to follow to exchange data; agreed upon format to send and receive messages between computing devices – Standard, Public , Private

- Standard – Published and controlled by a standards body (e.g. BACnet, html, xml)

- Public – Published and controlled by a private organization. Can be used by anyone freely or via license (e.g. LON, Modbus)

- Private or Proprietary – Unpublished and developed/controlled by a private organization

→ Open

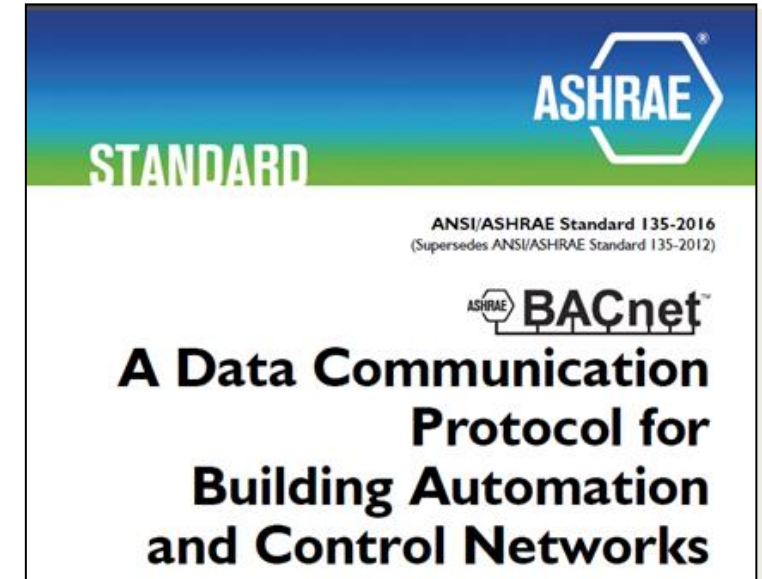

# Network Communication - BACnet

BACnet - A standard protocol published by a standards organization (American Society of Heating, Refrigerating and Air-conditioning Engineers or ASHRAE). It is a specification that defines what is required to conform to the protocol.

**B**uilding  
**A**utomation and  
**C**ontrol  
**n**etworks

Designed to provide communication and **interoperability** between **building** automation devices and applications

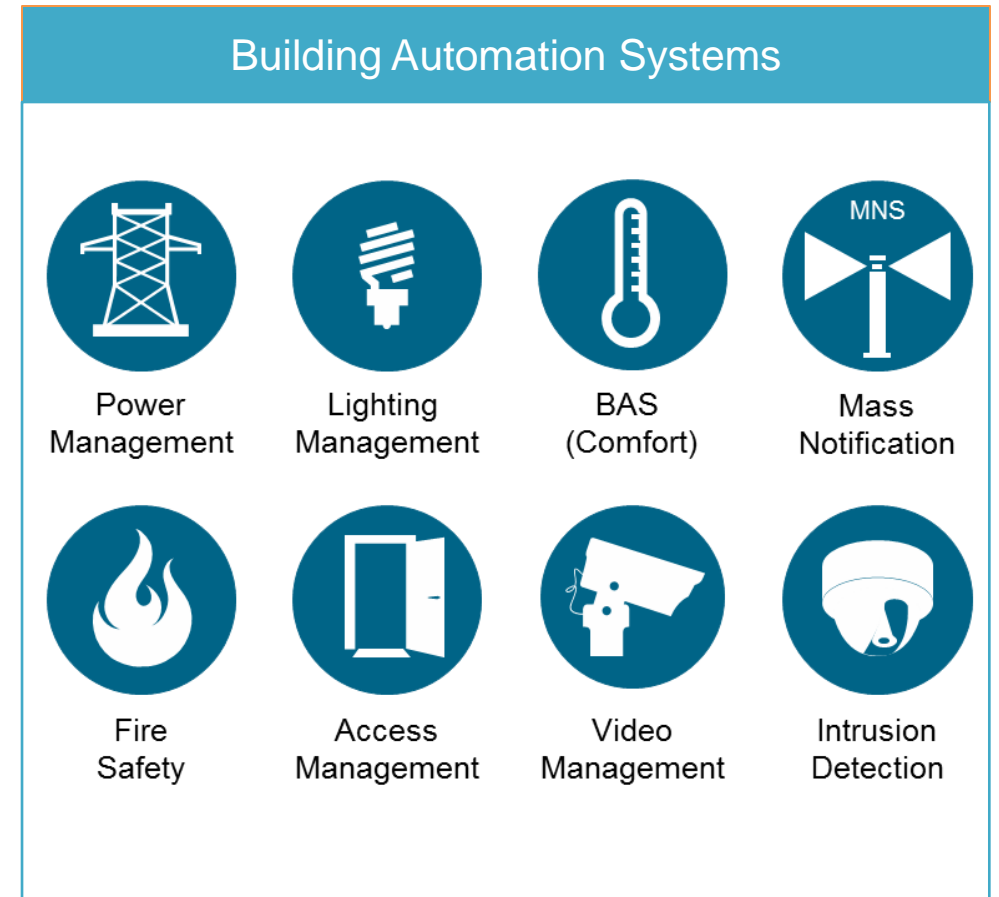

# Network Communication - BACnet

Objects: Represent information  
 Services: Requests and interoperation  
 Network Types: Transport systems

Analog Input Properties

Required	Object_Identifier	43
	Object_Name	SpaceTemp
	Object_Type	Analog-input
	Present_Value	72.3
	Status_Flags	Normal, InService
Optional	High_Limit	78.0
	Low Limit	62.0

## BACnet Standard Objects Sampling (60 total – 2016)

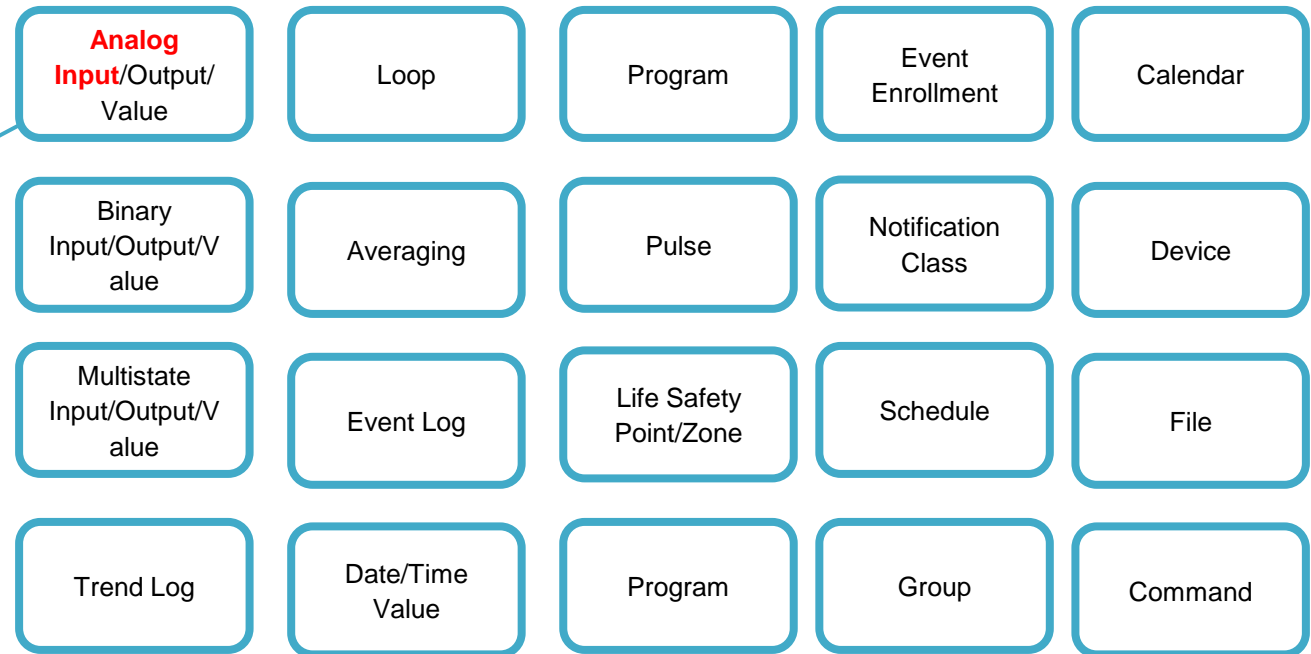

# BACnet Transport Protocols – Data Link/Physical Layers

Most Frequent Among BACnet Vendors

- BACnet Ethernet
- BACnet/IP
- MS/TP
- PTP
- LonTalk
- ARCnet

\*Zigbee

\***BACnet Secure Connect - New**

Protocol	Pros	Cons
Ethernet	<ul style="list-style-type: none"> <li>• Very Fast</li> <li>• Existing IP network</li> <li>• IT Familiarity</li> </ul>	<ul style="list-style-type: none"> <li>• IP routers block</li> </ul>
BACnet/IP	<ul style="list-style-type: none"> <li>• Very Fast</li> <li>• Existing IP network</li> <li>• Preferred for BACnet</li> </ul>	<ul style="list-style-type: none"> <li>• Broadcast messaging setup</li> </ul>
MS/TP	<ul style="list-style-type: none"> <li>• Low cost</li> <li>• Easy/familiar installation</li> <li>• Popular on lower tier</li> </ul>	<ul style="list-style-type: none"> <li>• Slower speed</li> </ul>

# Basic BACnet Networking

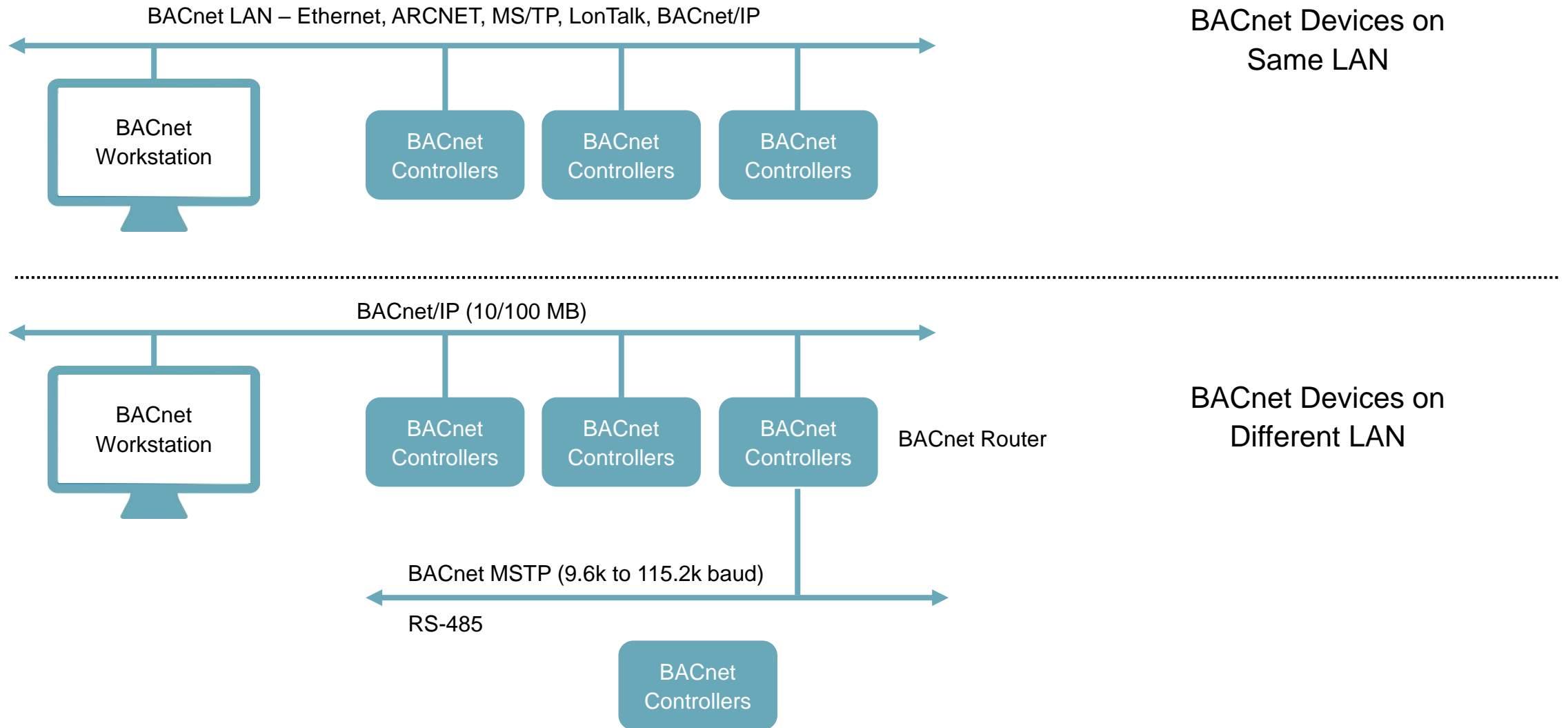

# Basic BACnet Networking

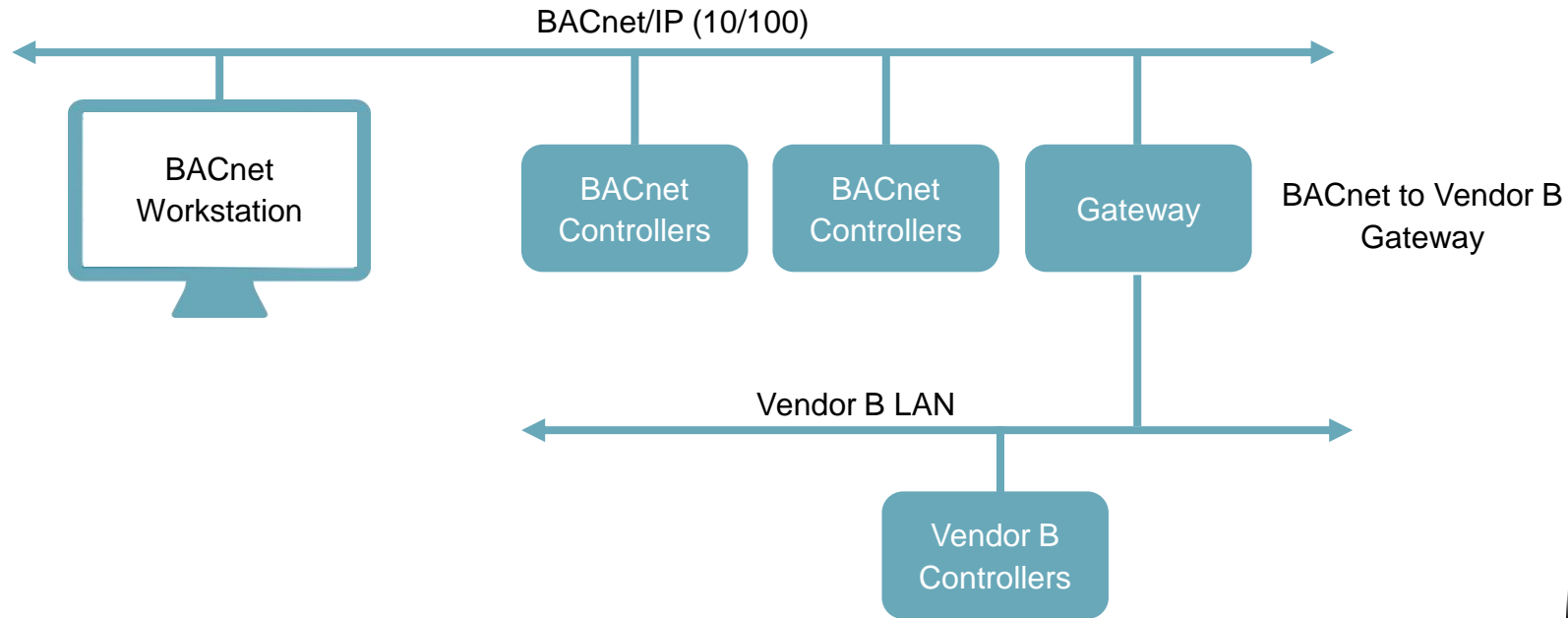

BACnet to Non-BACnet Devices  
(e.g. Modbus, BAS Legacy)



BTL Listing ensures products have been successful tested by the BTL

*\*ASHRAE does not test for compliance*

# Other Communication Protocols

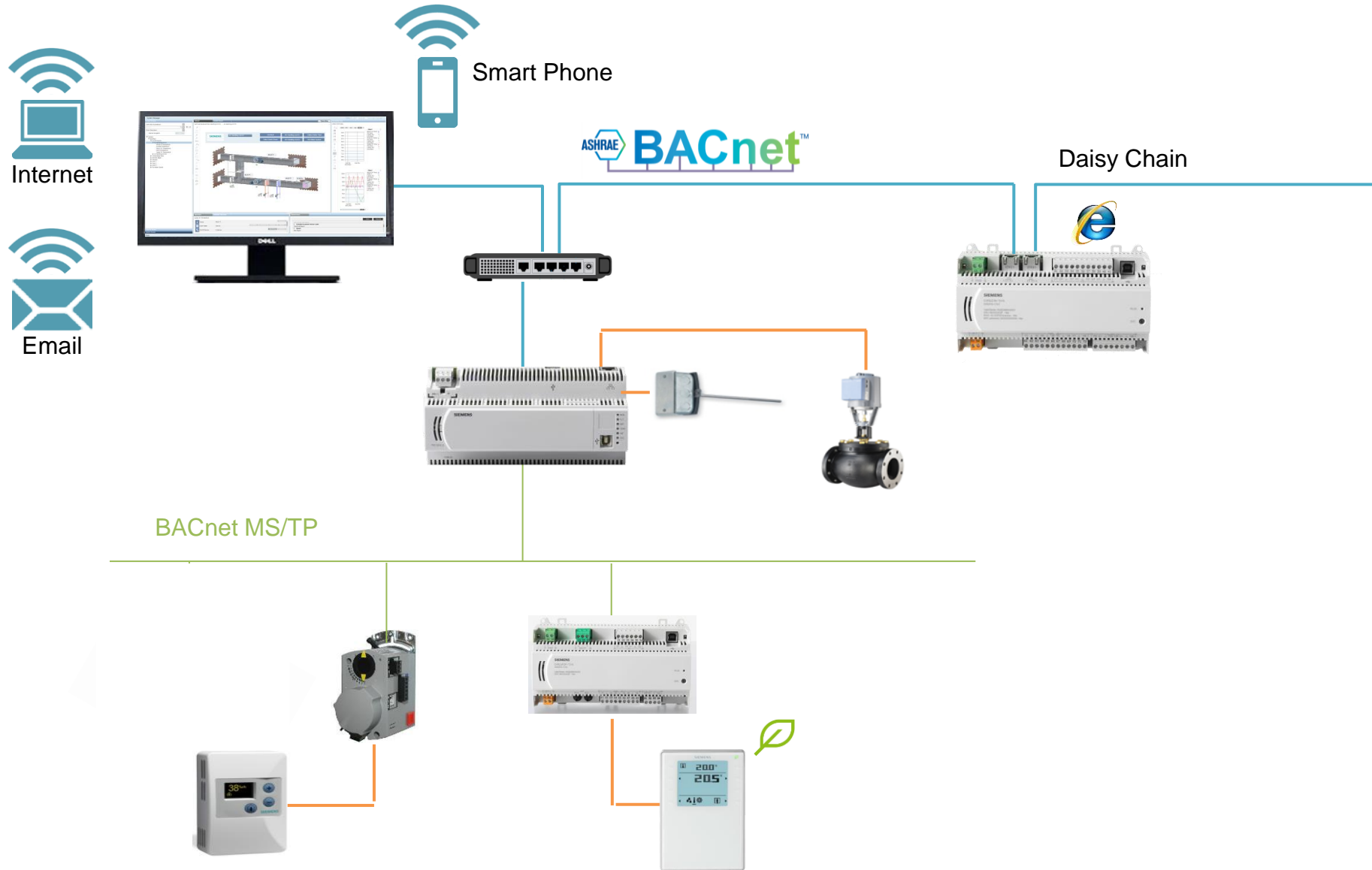

The image features a perspective view of a tunnel formed by concentric rings of binary code (0s and 1s) that recede into the distance. At the center of the tunnel is a bright, glowing white sphere. Overlaid on the right side of the image is a solid teal circle with a thin white border. Inside this circle, the word "Trends" is written in a clean, white, sans-serif font.

Trends

# Key Trends Affecting Building Systems Next Evolution

## Smart Buildings and Internet of Things (IoT)

- The global smart building market is expected to grow from \$72.6B (2021) to \$121.6B by 2026\*
- The internet and emerging tech are enabling this growth
- Increasing use of Division 25 specifications – more holistic view of integrated systems from conceptual phase through the final build.
- HVAC, lighting, security, life safety, and almost any conceivable building system have tapped into IoT and API integrations to the BAS
- Improve building life cycle performance, lower life cycle costs, deliver higher occupant satisfaction

## Big Data and Cloud Computing

- Unprecedented volume and detail of data – collect, transmit and analyze
- Data collection – intelligent field devices and systems
- Data transmission – frequently cloud based services
- Data analytics - a true analytic platform that can analyze data and monitor system performance

*\*MarketandMarkets global research and consulting firm*

# Architecture

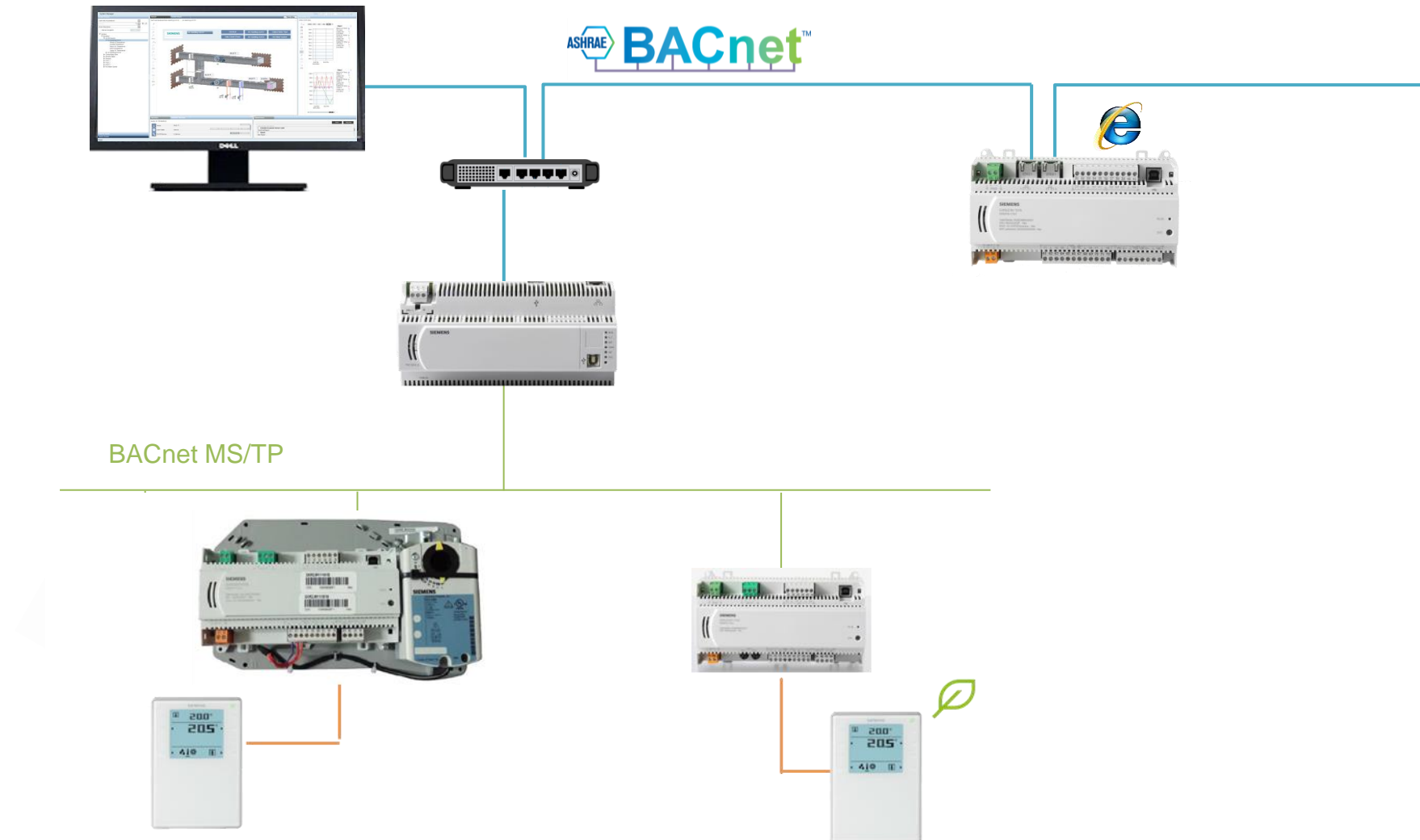

# Enterprise Level

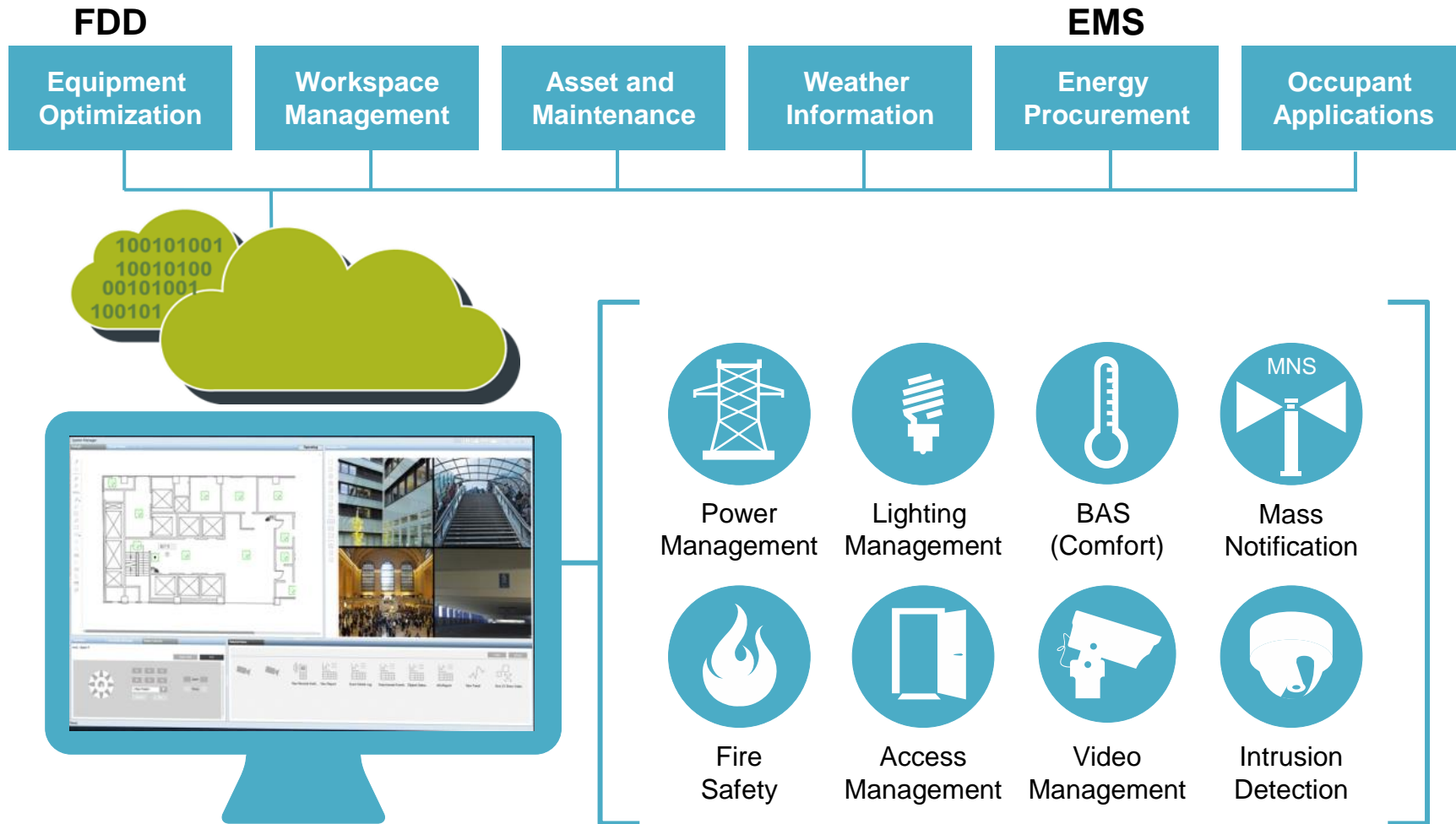

Integrated Building Management System (IBMS)

# Integrated Building Management System – IBMS

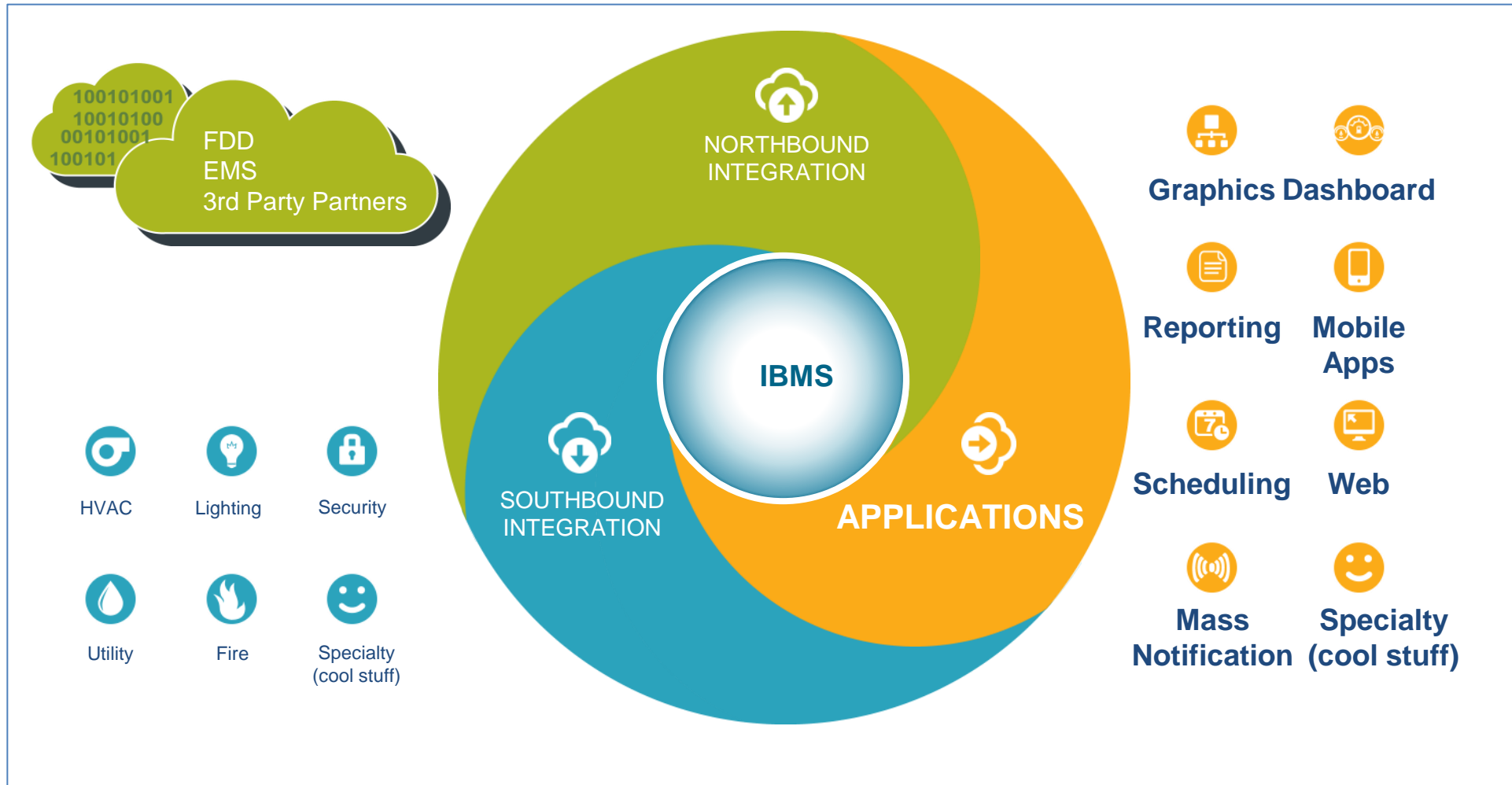

The image features a perspective view of a tunnel formed by rows of binary code (0s and 1s) that recede into the distance, creating a sense of depth. The code is rendered in a light blue/teal color against a darker background. In the center of the image, there is a large, solid teal circle with a thin white border. Inside this circle, the text "Wrap-up" is written in a clean, white, sans-serif font.

**Wrap-up**

## BAS Basics – Key Take-Aways

- Building Use, Technology and Occupants drive BAS Technology
- Devices become BAS points
- Control loop = Input + Processor + Output
- BACnet is the communication link ... ***BACnet Secure Connect (BACnet/SC)***

## Trends Summary

- Customers demanding more data for more users – Network Speed/Third party Apps
- Staffing issues driving FDD (Fault Detection Diagnostics)
- Smart Buildings driving Room and Level System Integration
- Cloud based services – Enterprise Level Applications

# BAS Basics

## Resources:

- ASHRAE Handbook:
  - Fundamentals
    - Chapter 7: Fundamentals of Control
  - HVAC Applications
    - Chapter 40: Computer Applications (BAS architecture, Networking, communications)
    - Chapter 42: Supervisory Control Strategies and Optimization (CPOP)
    - Chapter 47: Design and Application of Controls
- ASHRAE Guideline 13-2015: Specifying Direct Digital Control Systems
- Frank Shadpour, P.E. – The Fundamentals of HVAC Direct Digital Control (Practical Applications and Design)
- [www.DDC-Online.org](http://www.DDC-Online.org)

# Questions

# Thank you for attending!



# | Contact

Brendan Cox  
Sr. Sales Account Executive  
Siemens | Smart Infrastructure  
104 Sebethe Drive  
Cromwell, CT 06416  
USA

Mobile 860-262-2784

E-mail [brendan.cox@siemens.com](mailto:brendan.cox@siemens.com)